

Neural Networks for Machine Learning History and Concepts

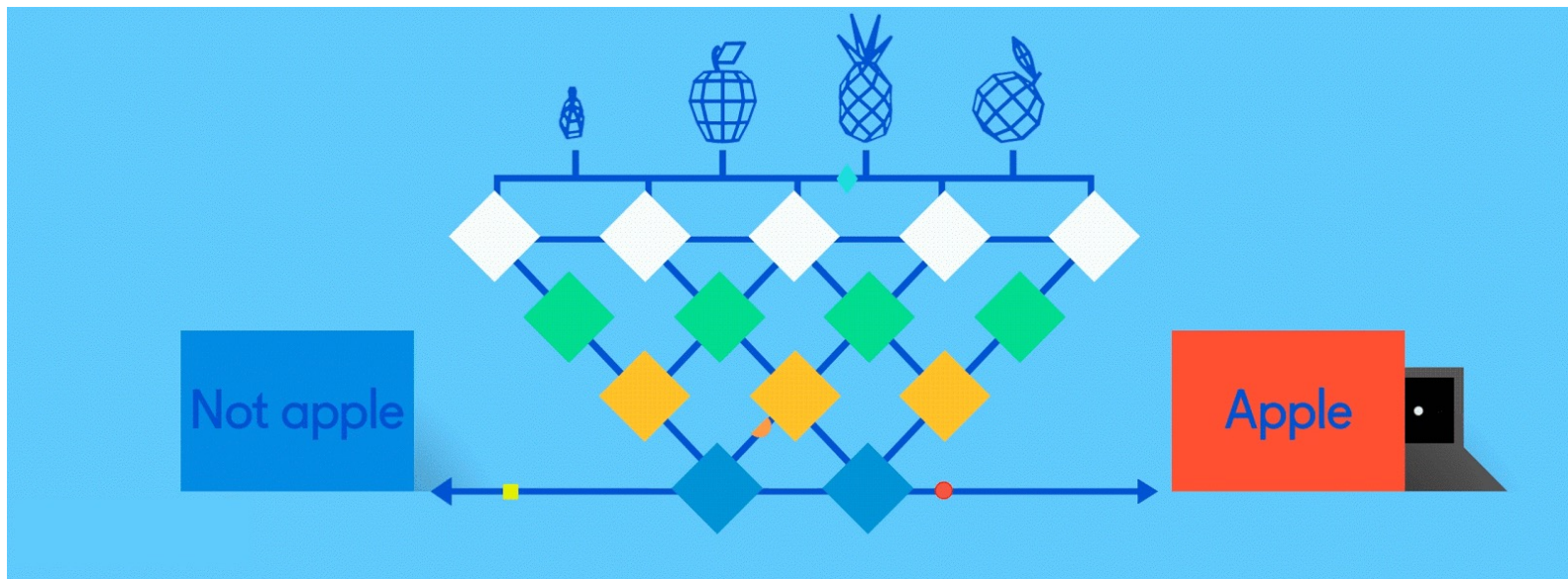

Overview

- The neural network computing model has a long history
- Evolved over 75 years to solve its inherent problems, becoming the dominant model for machine learning in the 2010s
- Neural network models typically give better results than all earlier ML models
- But they are expensive to train and apply
- The field is still evolving rapidly

Deep Learning Timeline

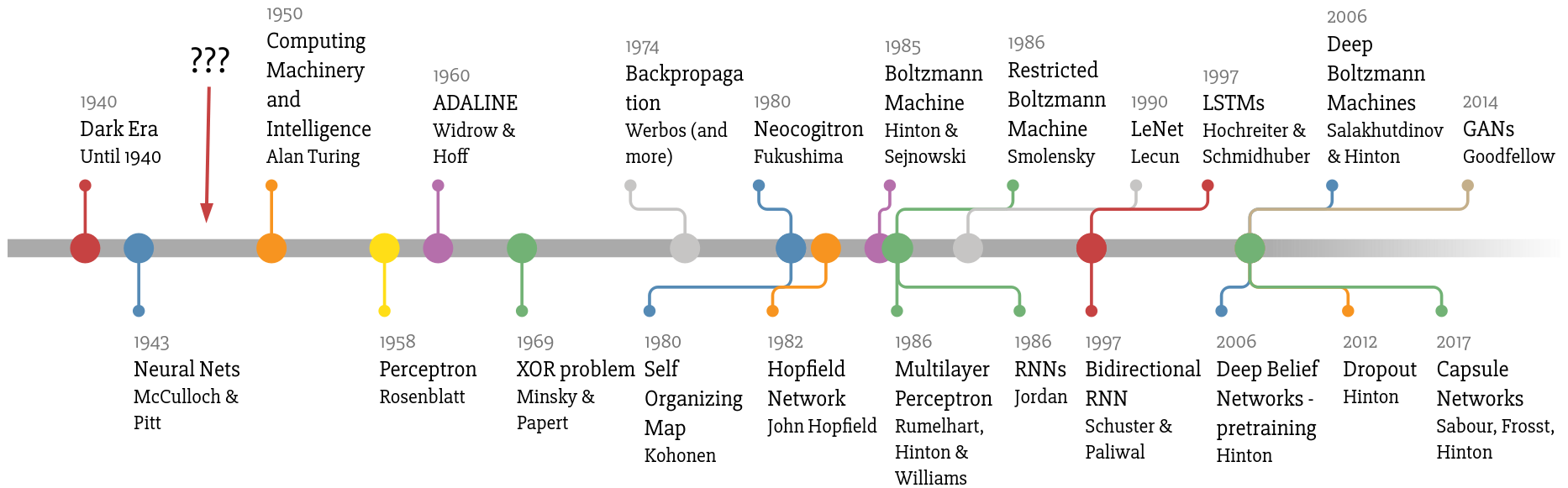

Made by Favio Vázquez

How do animal brains work?

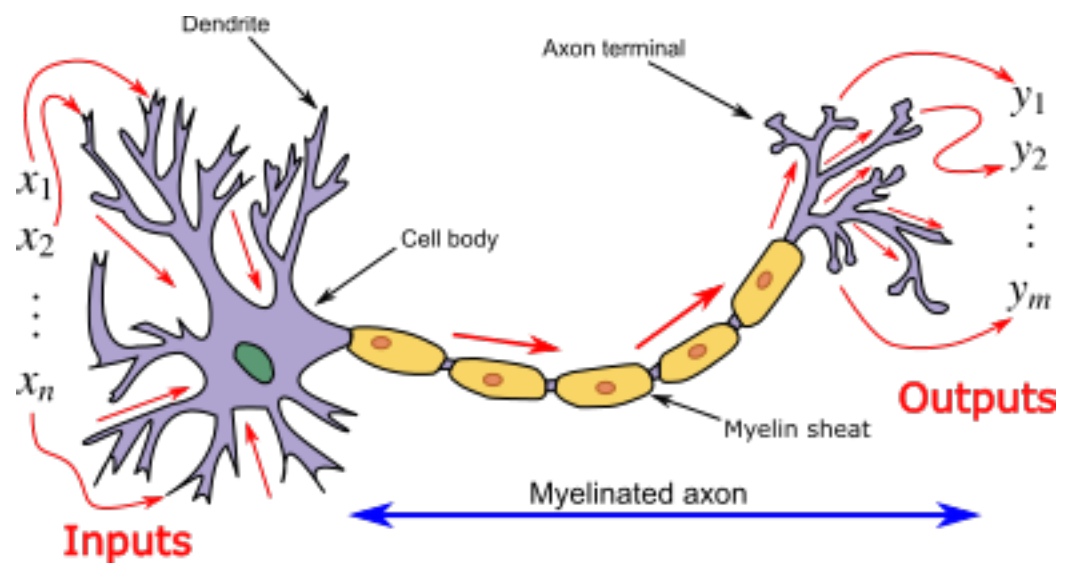

Neuron and myelinated axon, with signal flow from inputs at dendrites to outputs at axon terminals

Neurons have body, axon and many dendrites

- In one of two states: firing and rest
- They fire if total incoming stimulus $>$ threshold

Synapse: thin gap between axon of one neuron and dendrite of another

- Signal exchange

McCulloch & Pitts

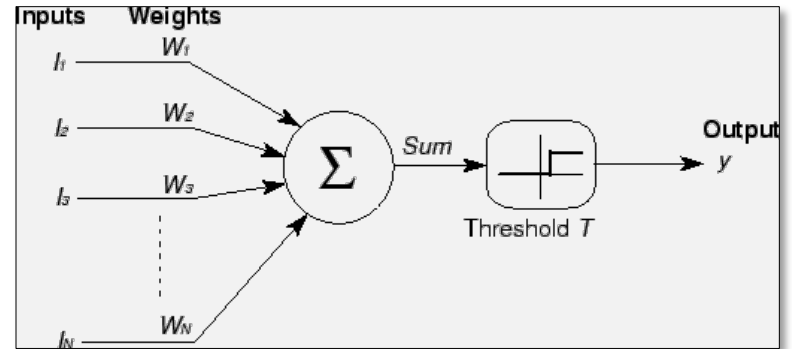

- First mathematical model of biological neurons, **1943**
- All Boolean operations can be implemented by these neuron-like nodes
- Competitor to Von Neumann model for general purpose computing device
- Origin of automata theory

Artificial neural network

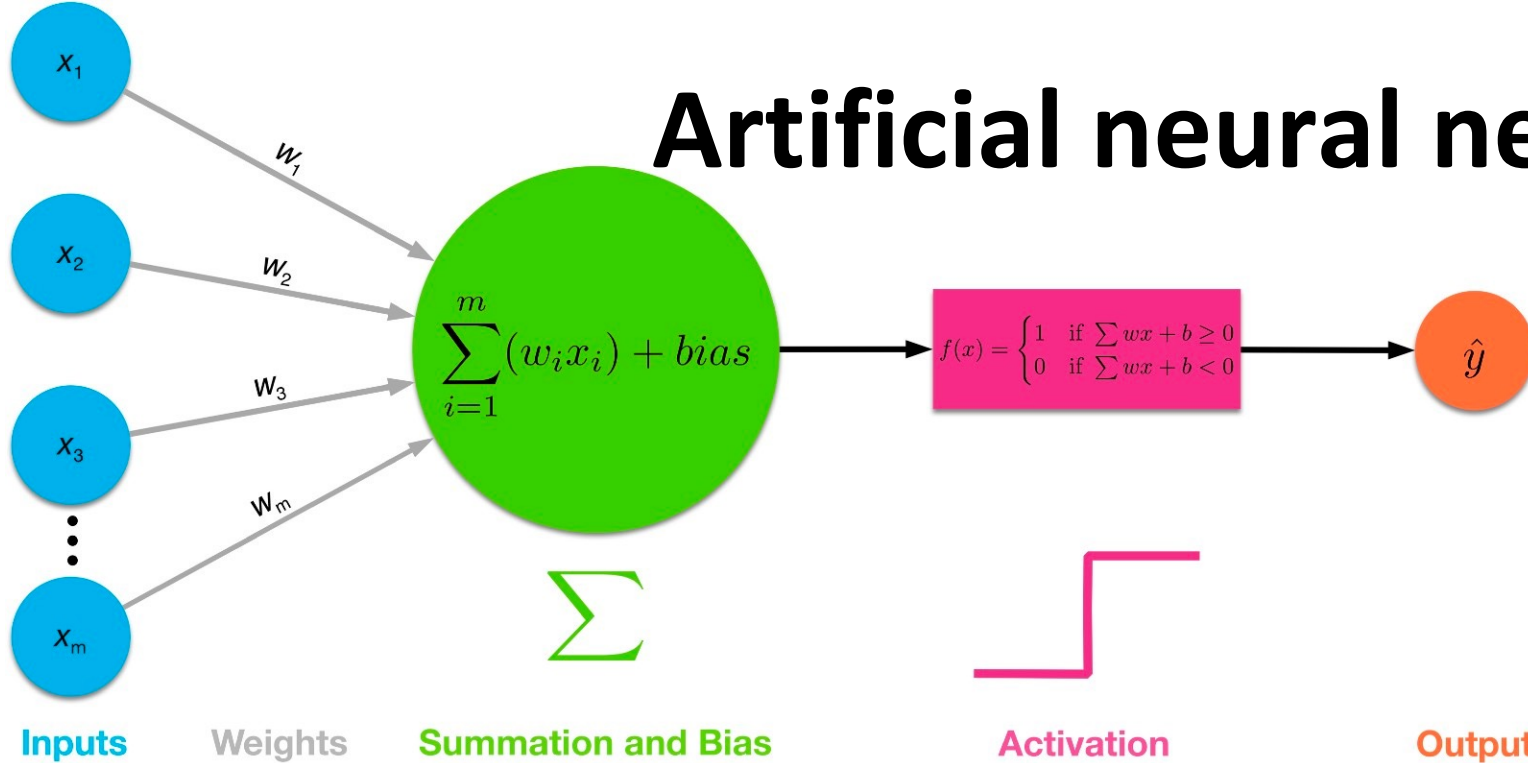

- Model still used today!
- Set of **nodes** with inputs and outputs
- Node performs computation via an **activation function**
- **Weighted connections** between nodes
- Connectivity gives network architecture
- NN computations depend on connections, weights, and activation function

Common Activation Functions

defines the output of that node given an input

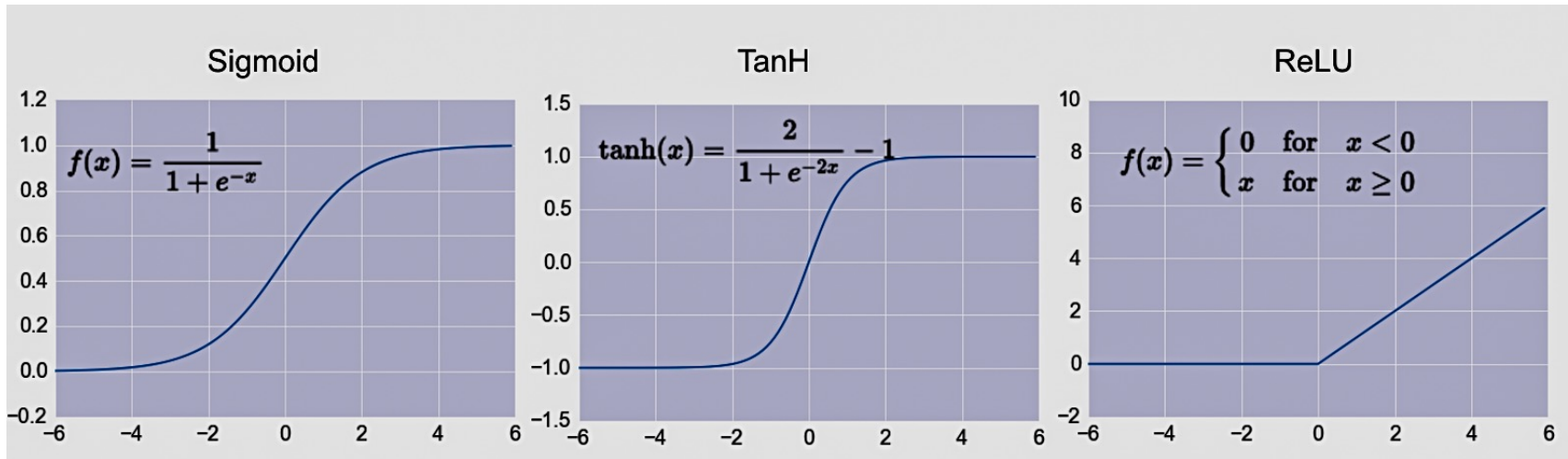

Choice of activation function depends on problem and available computational power

Rosenblatt's perceptron (1958-60)

- Single layer network of nodes
- Real valued weights +/-
- Supervised learning using a simple learning rule

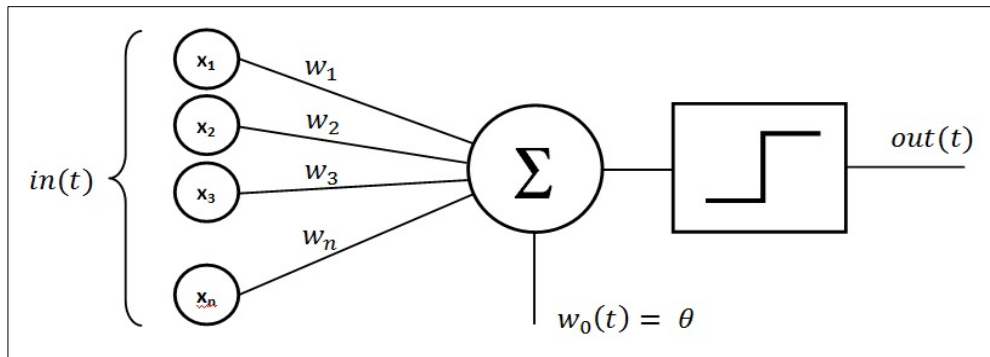

- Essentially a linear classifier
- Widrow & Hoff (1960-62) added better learning rule using gradient descent

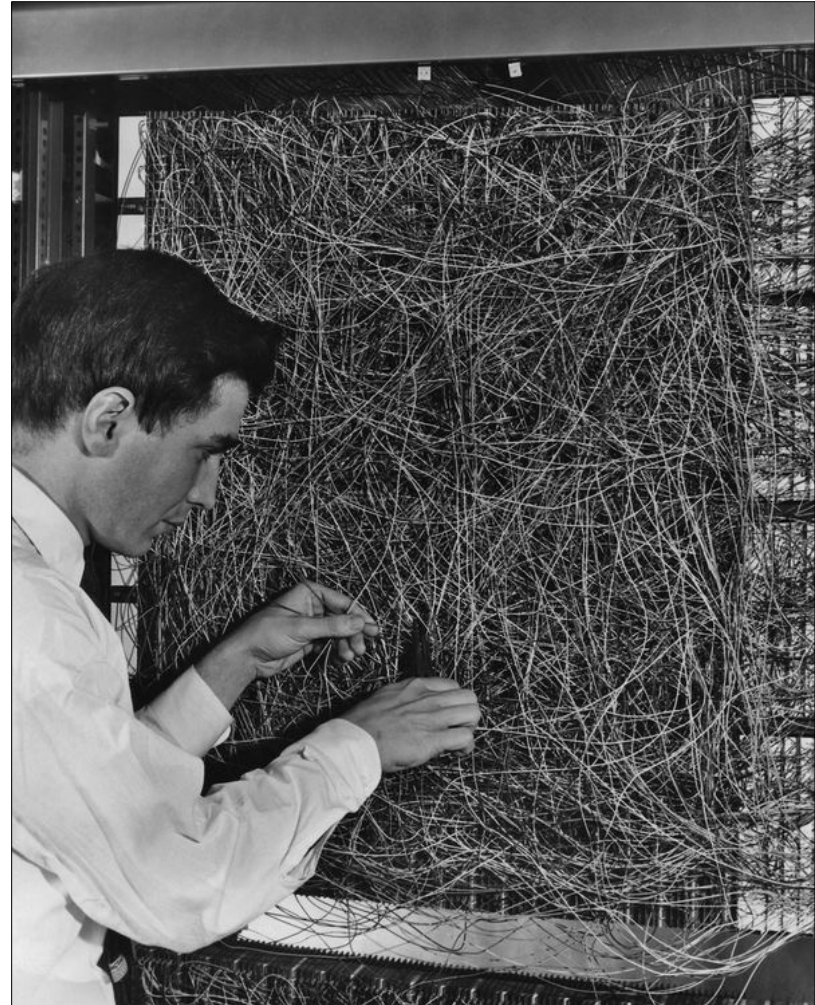

Mark 1 perceptron computer, Cornell Aeronautical Lab, 1960

Single Layer Perceptron

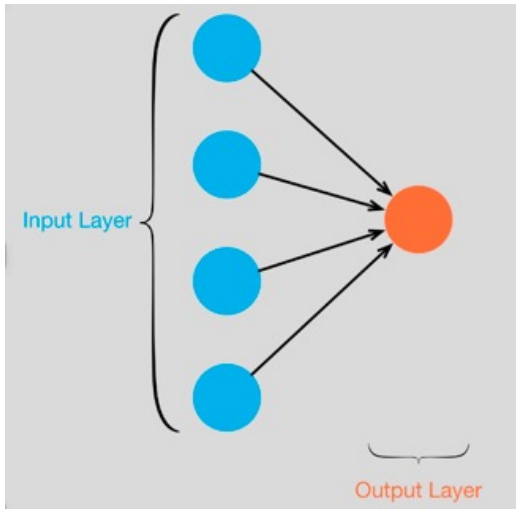

NEW NAVY DEVICE LEARNS BY DOING; Psychologist Shows Embryo of Computer Designed to Read and Grow Wiser

SPECIAL TO THE NEW YORK TIMES JULY 8, 1958



WASHINGTON, July 7 (UPI) -- The Navy revealed the embryo of an electronic computer today that it expects will be able to walk, talk, see, write, reproduce itself and be conscious of its existence.

- See the full 1958 NYT article above [here](#)
- Rosenblatt: it can **learn** to compute functions by learning weights on inputs from examples

Setback in mid 60s – late 70s

- [Perceptrons](#), Minsky and Papert, 1969
- Described serious problems with perceptron model
 - Single-layer perceptrons cannot represent (learn) simple functions that are not linearly separable, such as XOR
 - Multi-layers of non-linear units may have greater power but there is no *learning rule* for such nets
 - Scaling problem: connection weights may grow infinitely
 - First two problems overcame by latter effort in 80s, but scaling problem persists
- Death of Rosenblatt (1964)
- AI focused on programming intelligent systems on traditional von Neuman computers

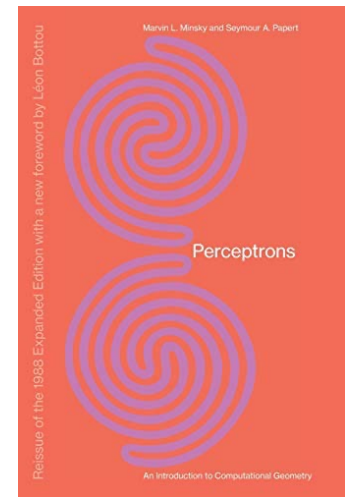

Not with a perceptron ☹️

Consider Boolean operators (and, or, xor) with four possible inputs: 00 01 10 11

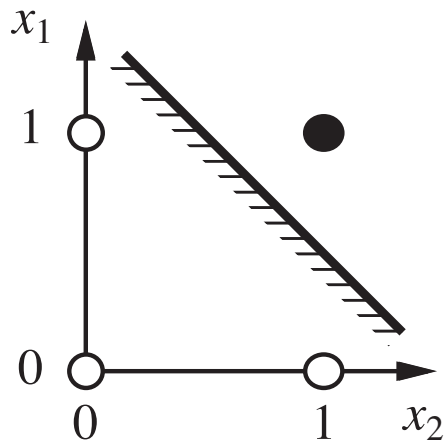

(a) x_1 and x_2

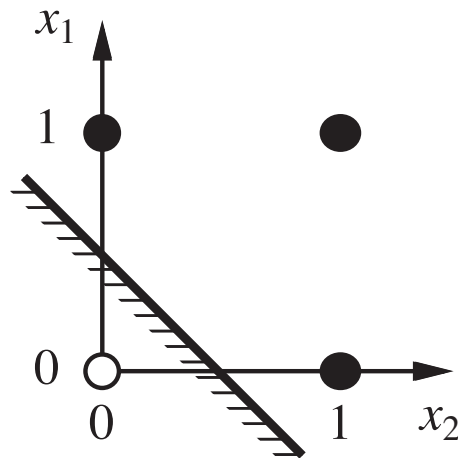

(b) x_1 or x_2

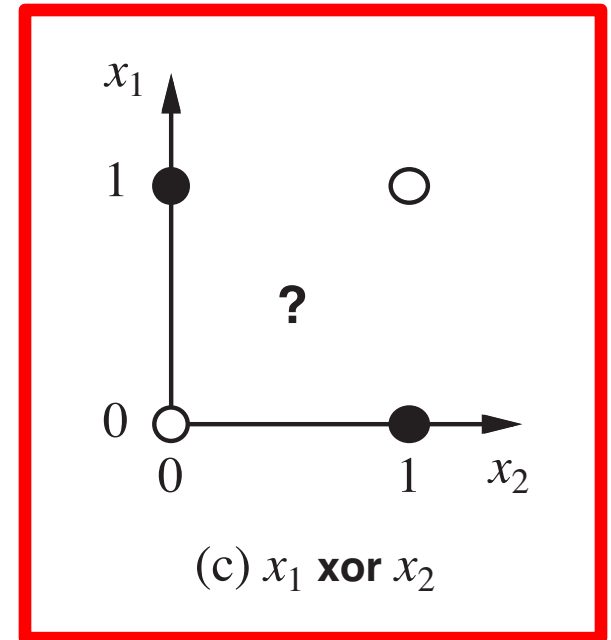

(c) x_1 xor x_2

Training examples are **not linearly separable**
for one case: $sum=1$ iff x_1 xor x_2

Renewed enthusiasm 1980s

- Use multi-layer perceptron
- [Backpropagation](#) for multi-layer feed forward nets, with non-linear, differentiable node functions
 - Rumelhart, Hinton, Williams, [Learning representations by back-propagating errors](#), Nature, 1986.
- Other ideas:
 - Thermodynamic models (Hopfield net, Boltzmann machine ...)
 - Unsupervised learning
- Applications to character recognition, speech recognition, text-to-speech, etc.

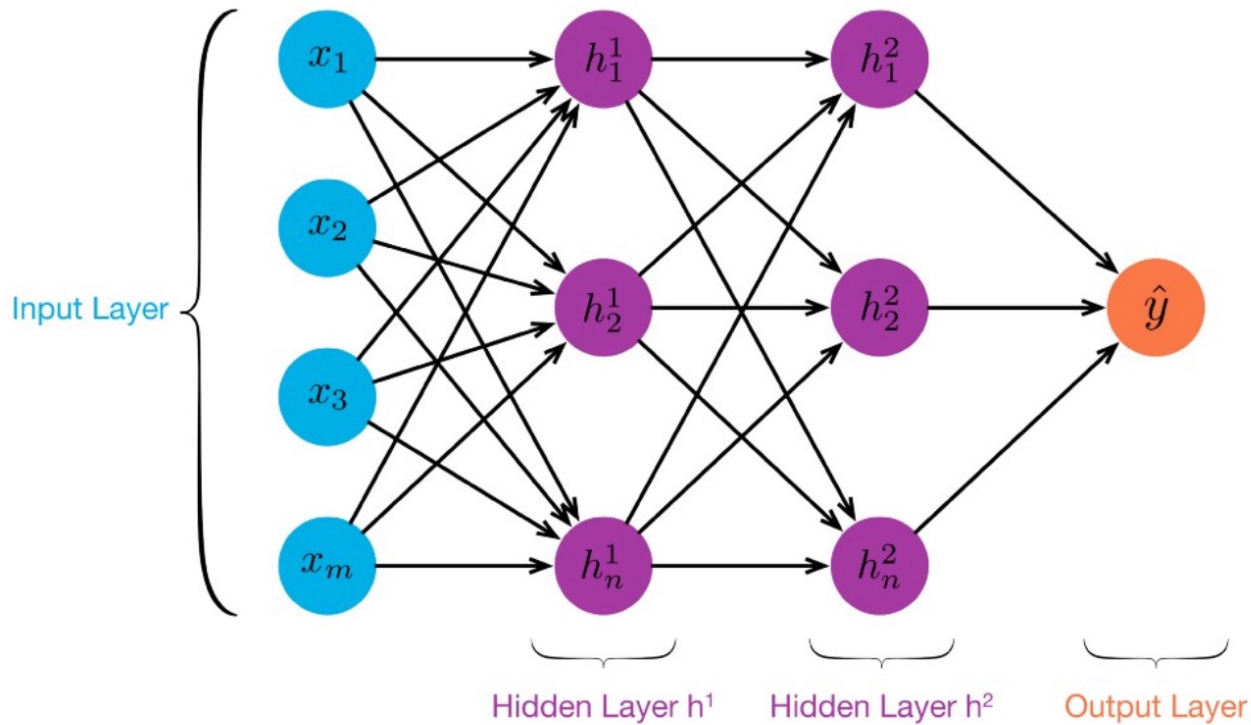

MLP: Multilayer Perceptron

- ≥ 1 “hidden layers” between inputs & output
- Can compute **non-linear functions** (why?)
- Training: adjust weights slightly to reduce error between output \mathbf{y} and target value \mathbf{t} ; repeat
- Introduced in 1980s, still used today

Feed Forward Neural Network

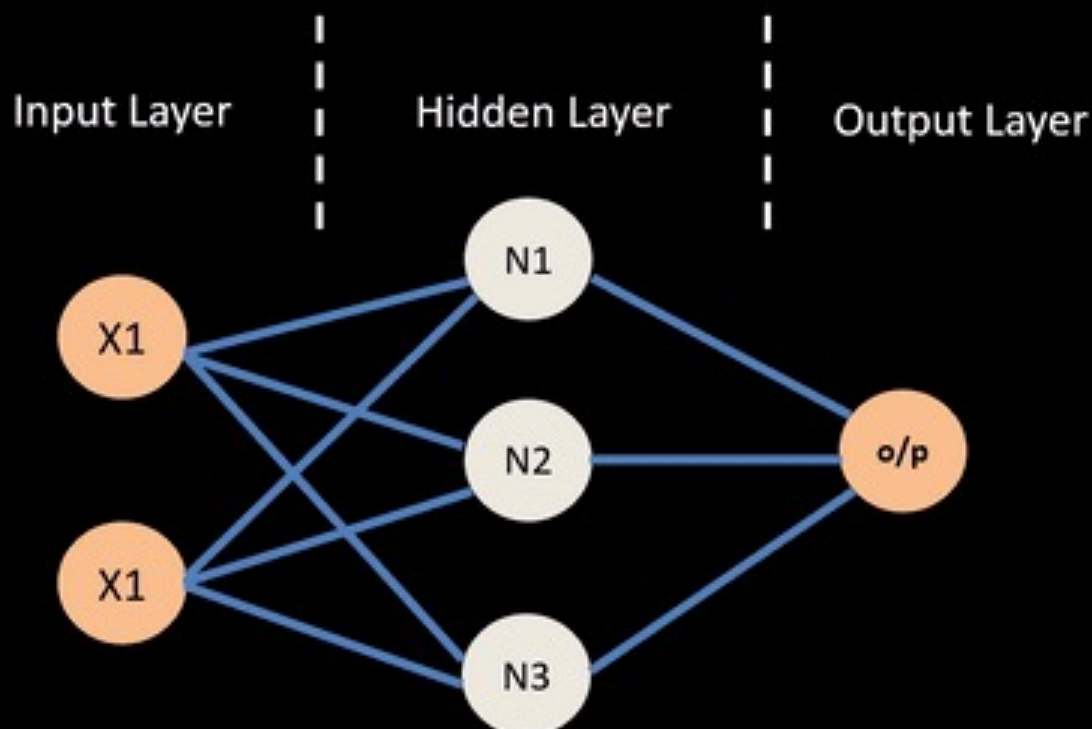

Information flows in forward direction only

Neural Network – Backpropagation

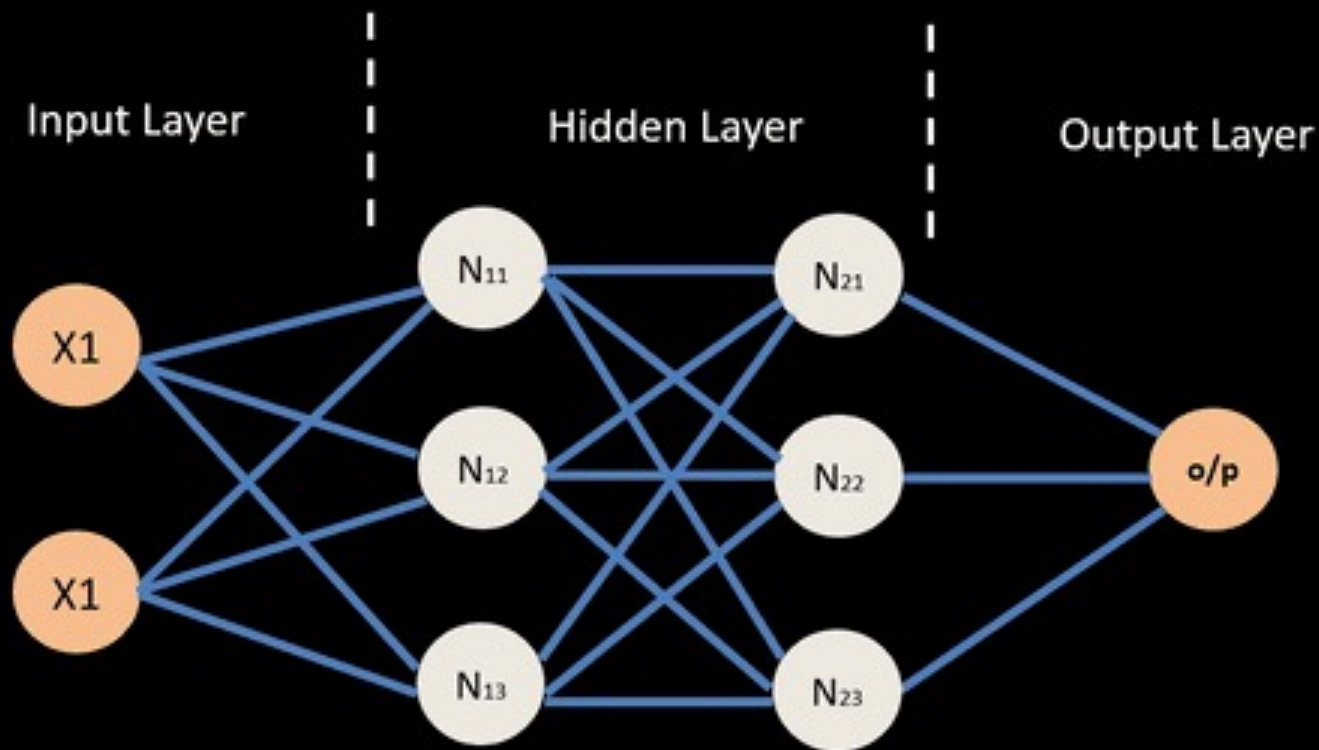

Backpropagation Explained

Click on image (or [here](#)) for a simple interactive demo in your browser of how [backpropagation](#) updates weights in a neural network to reduce errors when processing training data

Simple neural network

On the right, you see a neural network with one input, one output node and two hidden layers of two nodes each.

Nodes in neighboring layers are connected with weights w_{ij} , which are the network parameters.

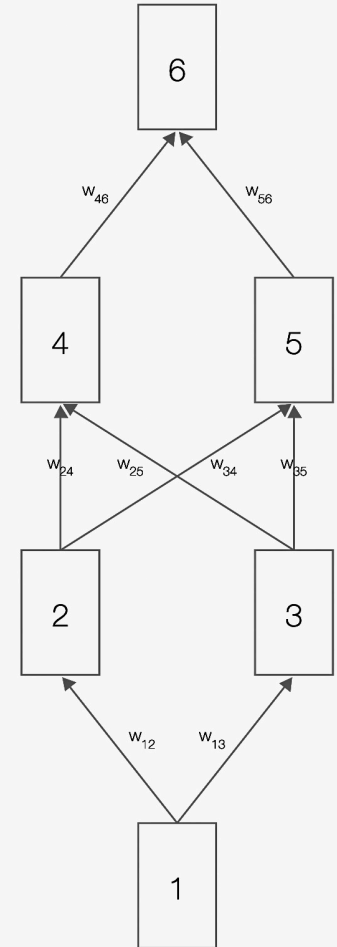

But problems remained ...

- It's often the case that solving a problem just reveals a new one that needs solving
- For a large MLPs, backpropagation takes forever to converge!
- Two issues:
 - Not enough compute power to train the model
 - Not enough labeled data to train the neural net
- SVMs dominate, since they converge to global optimum in $O(n^2)$

GPUs solve compute power problem

- GPUs (Graphical Processing Units) became popular in the 1990s to handle computing needed for better computer graphics
- GPUs are SIMD (single instruction, multiple data) processors
- Cheap, fast, and easy to program
- GPUs can do matrix multiplication very fast



Need lots of data!

- 2000s introduced big data
- Cheaper storage
- Parallel processing (e.g., MapReduce, Hadoop, Spark)
- Data sharing via the Web
 - Lots of images, many with captions
 - Lots of text, some with labels
- Crowdsourcing systems (e.g., [Mechanical Turk](#)) provided a way to get more labels

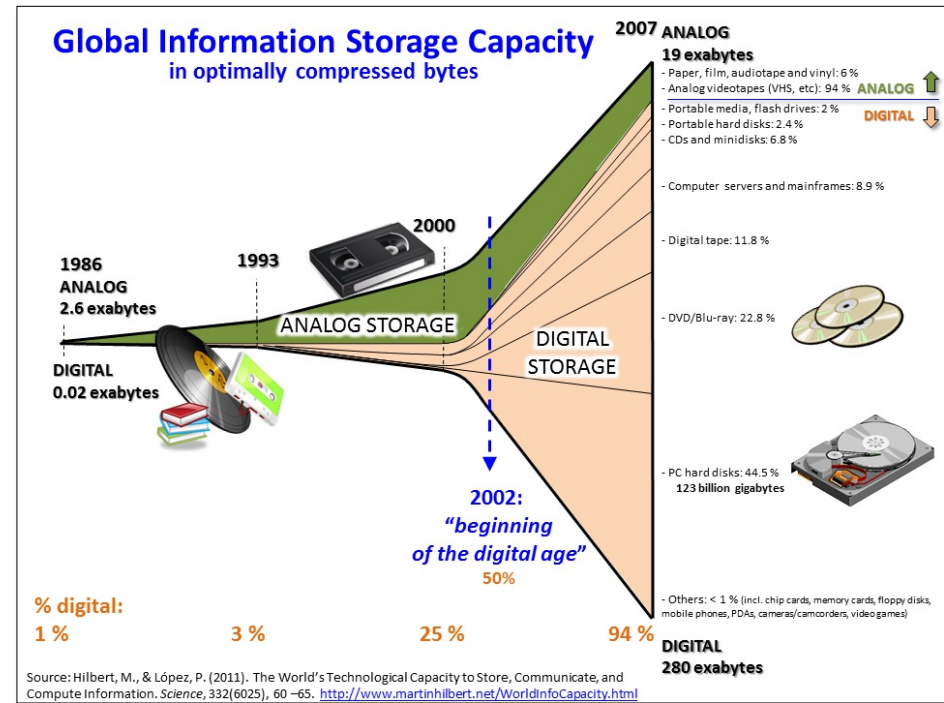

New problems are surfaced

- 2010s was a decade of domain applications
- These came with new problems, e.g.,
 - Images are too high dimensional!
 - Variable-length problems cause gradient problems
 - Training data is rarely labeled
 - Neural nets are uninterpretable
 - Training complex models required days or weeks
- This led to many new “deep learning” neural network models

Deep Learning

- Deep learning refers to models going beyond simple feed-forward multi-level perceptron
 - Though it was used in a ML context as early as 1986
- “deep” refers to the models having many layers (e.g., 10-20) that do different things

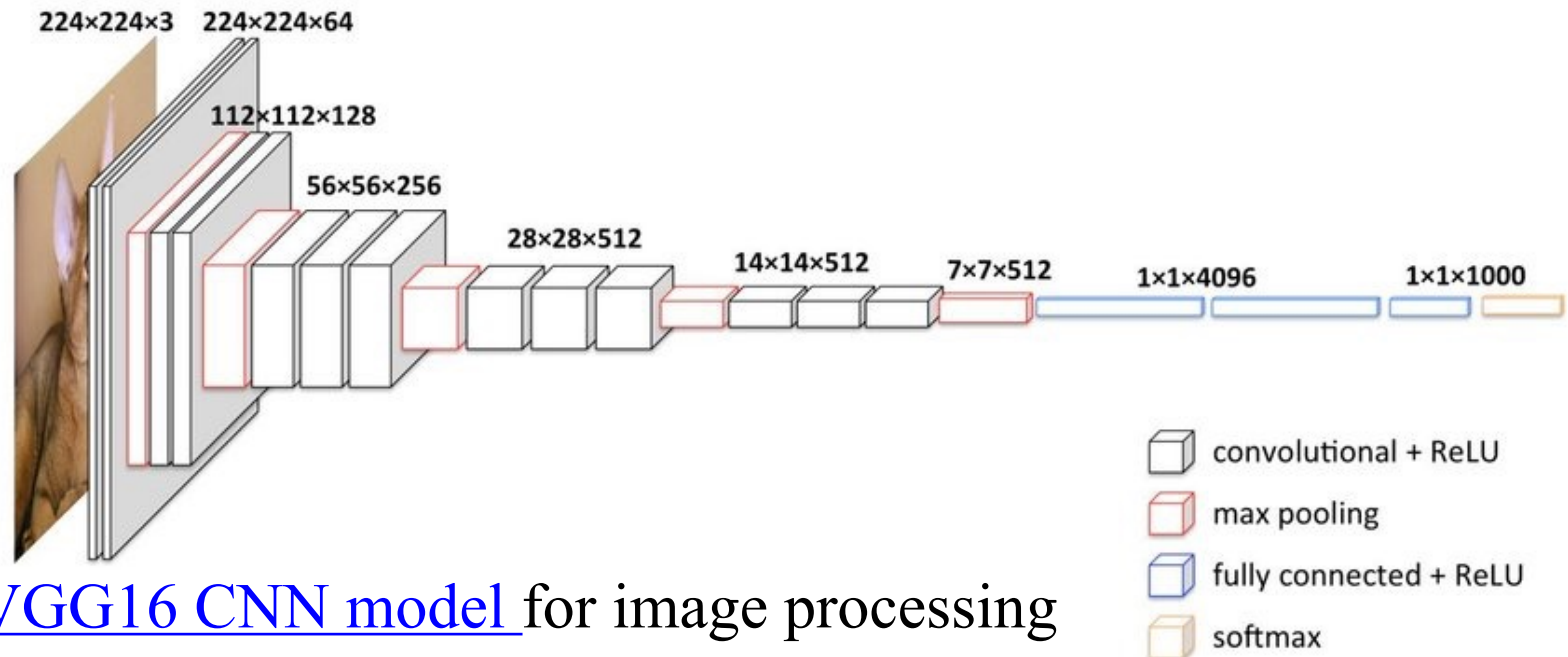

The [VGG16 CNN model](#) for image processing

Neural Network Architectures

Current focus on large networks with different “architectures” suited for different kinds of tasks

- Feedforward Neural Network
- CNN: **C**onvolutional **N**eural **N**etwork
- RNN: **R**ecurrent **N**eural **N**etwork
- LSTM: **L**ong **S**hort **T**erm **M**emory
- GAN: **G**enerative **A**dversarial **N**etwork
- Transformers: generating output sequence from input sequence

Feedforward Neural Network

- Connections allowed from a node in layer i only to nodes in layer $i+1$
i.e., no cycles or loops
- Simple, widely used architecture, provides a good baseline

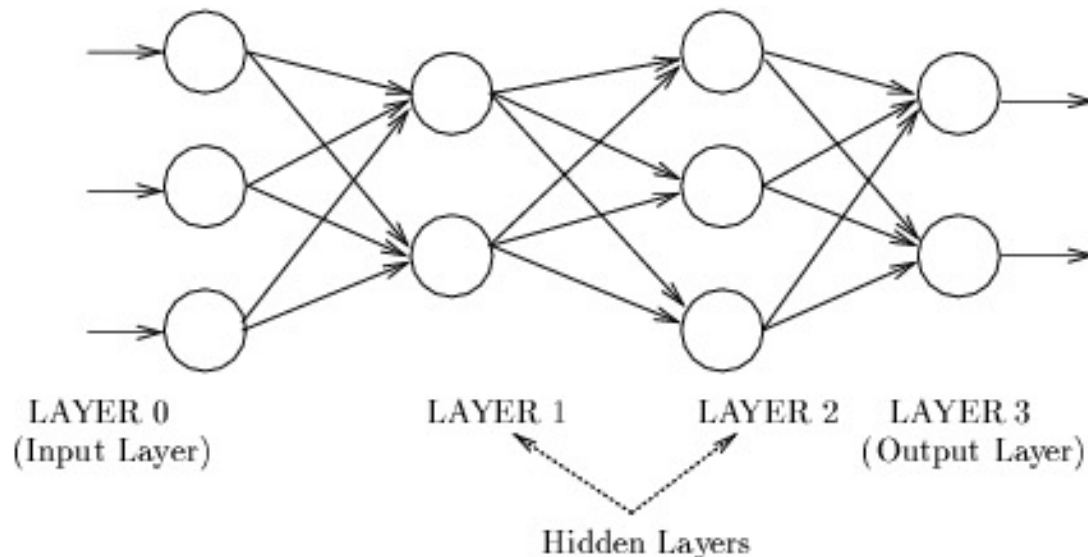

downstream nodes
tend to successively
abstract features from
preceding layers

Tinker With a **Neural Network** Right Here in Your Browser. Don't Worry, You Can't Break It. We Promise.



Epoch
000,000

Learning rate
0.03

Activation
ReLU

Regularization
None

Regularization rate
0

Problem type
Classification

DATA

Which dataset do you want to use?



Ratio of training to test data: 50%



Noise: 0



Batch size: 10



REGENERATE

FEATURES

Which properties do you want to feed in?

- X_1
- X_2
- X_1^2
- X_2^2
- $X_1 X_2$
- $\sin(X_1)$
- $\sin(X_2)$

2 HIDDEN LAYERS

+ -

4 neurons

+ -

2 neurons

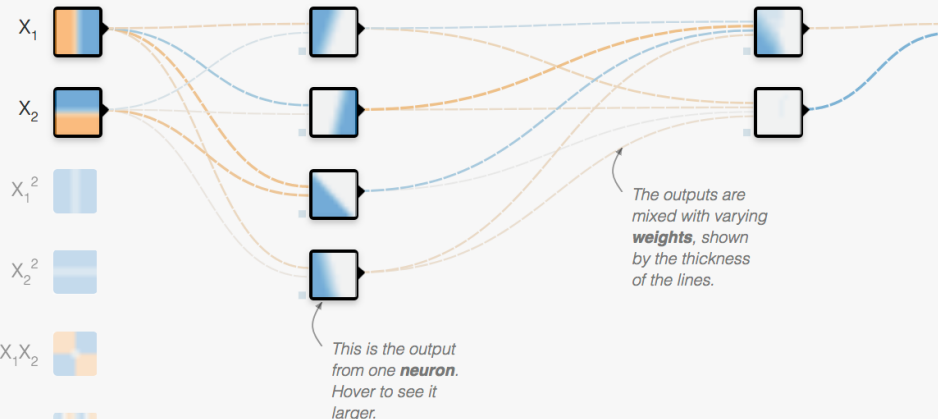

OUTPUT

Test loss 0.435
Training loss 0.432

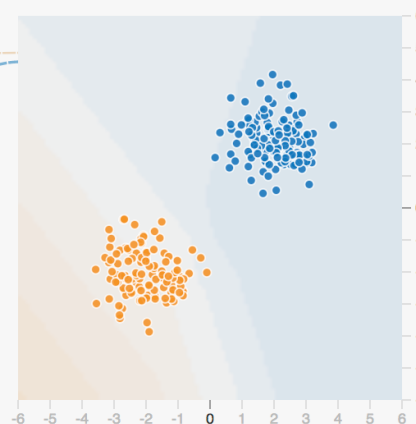

Colors shows data, neuron and weight values.

Show test data Discretize output

CNN: Convolutional Neural Network

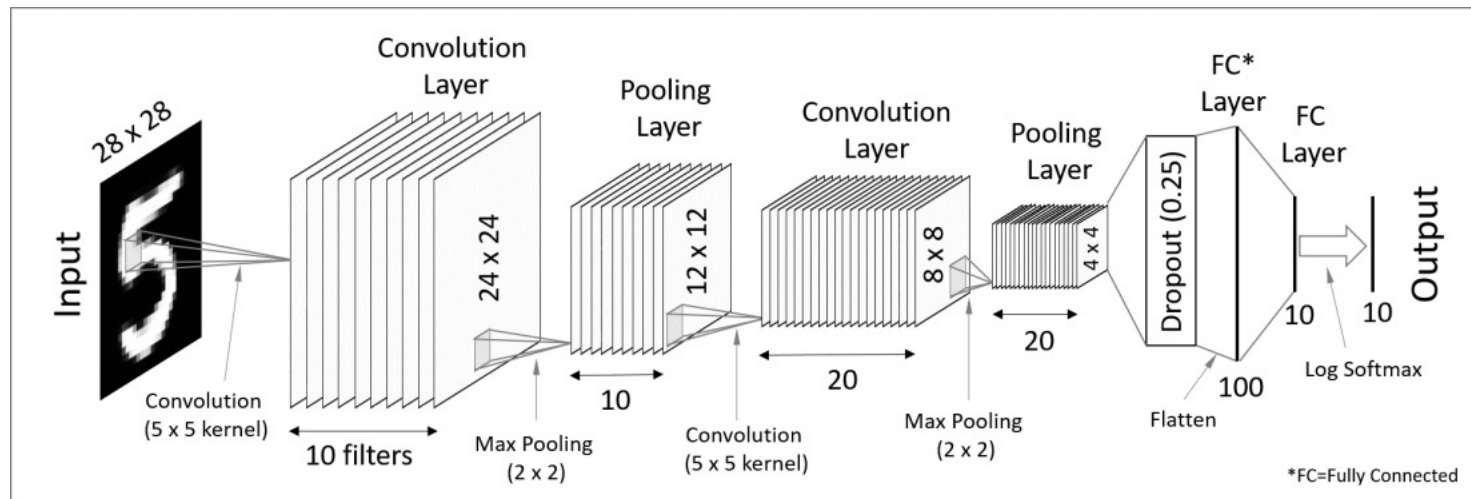

- Good for 2D image processing: classification, object recognition, automobile lane tracking, etc.
- Successive convolution layers learn higher-level features
- Classic demo: learn to recognize hand-written digits from [MNIST](#) data with 70K examples

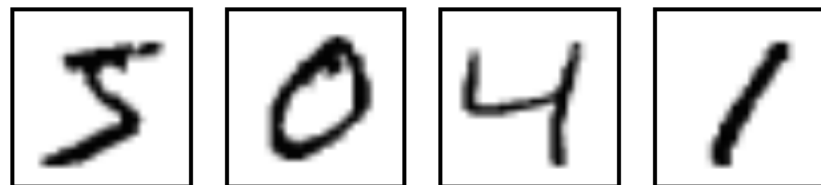

RNN: Recurrent Neural Networks

- Good for learning over sequences of data, e.g., a sentence of words
- LSTM (Long Short Term Memory) a popular architecture

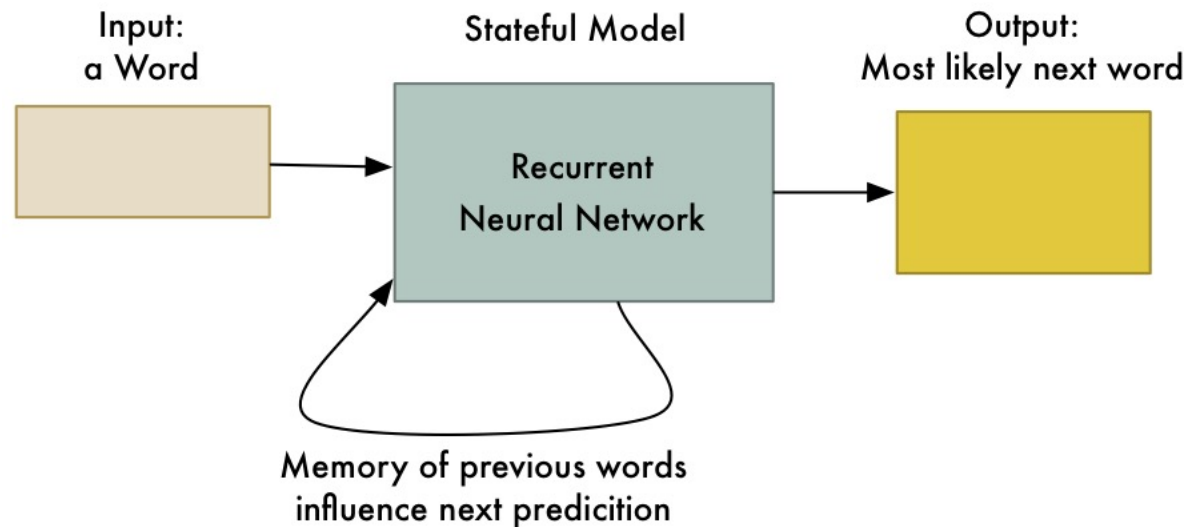

Output so far:
Machine

gif from [Adam Geitgey](#)

GAN: Generative Adversarial Network

- System of **two neural networks** competing against each other in a zero-sum game framework
- Provides a kind of **unsupervised learning** that improves the network
- Introduced by Ian Goodfellow et al. in 2014
- Can learn to draw samples from a model that is similar to data that we give them

Transformer

- Introduced in 2017
- Used primarily for natural language processing tasks
- NLP applications “transform” an input text into an output text
 - E.g., translation, text summarization, question answering
- Uses encoder-decoder architecture
- Popular pretrained models available, e.g. [BERT](#) and [GPT](#)

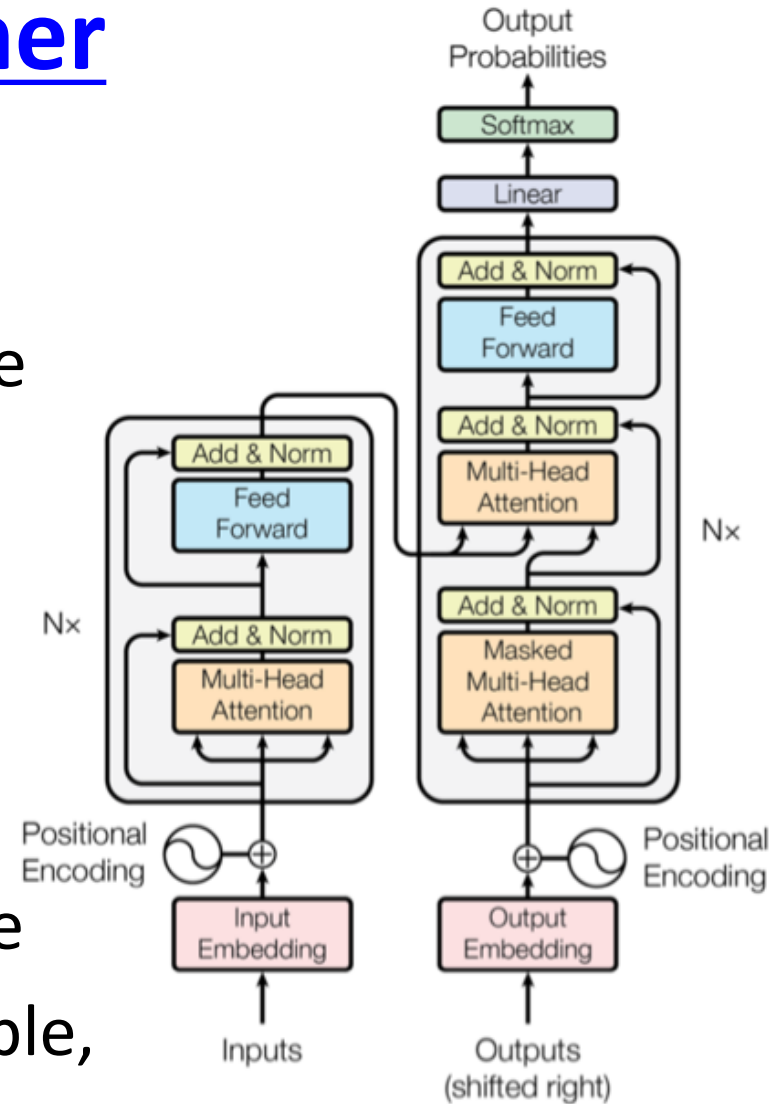

Deep Learning Frameworks (1)

- Popular open-source deep learning frameworks use Python at top-level; C++ in backend
 - [TensorFlow](#) (via Google)
 - [PyTorch](#) (via Facebook)
 - [MxNet](#) (Apache)
 - [Caffe](#) (Berkeley)
- TensorFlow and PyTorch now dominate; both make it easy to specify a complicated network

Deep Learning Frameworks (2)

See this article for a good comparison

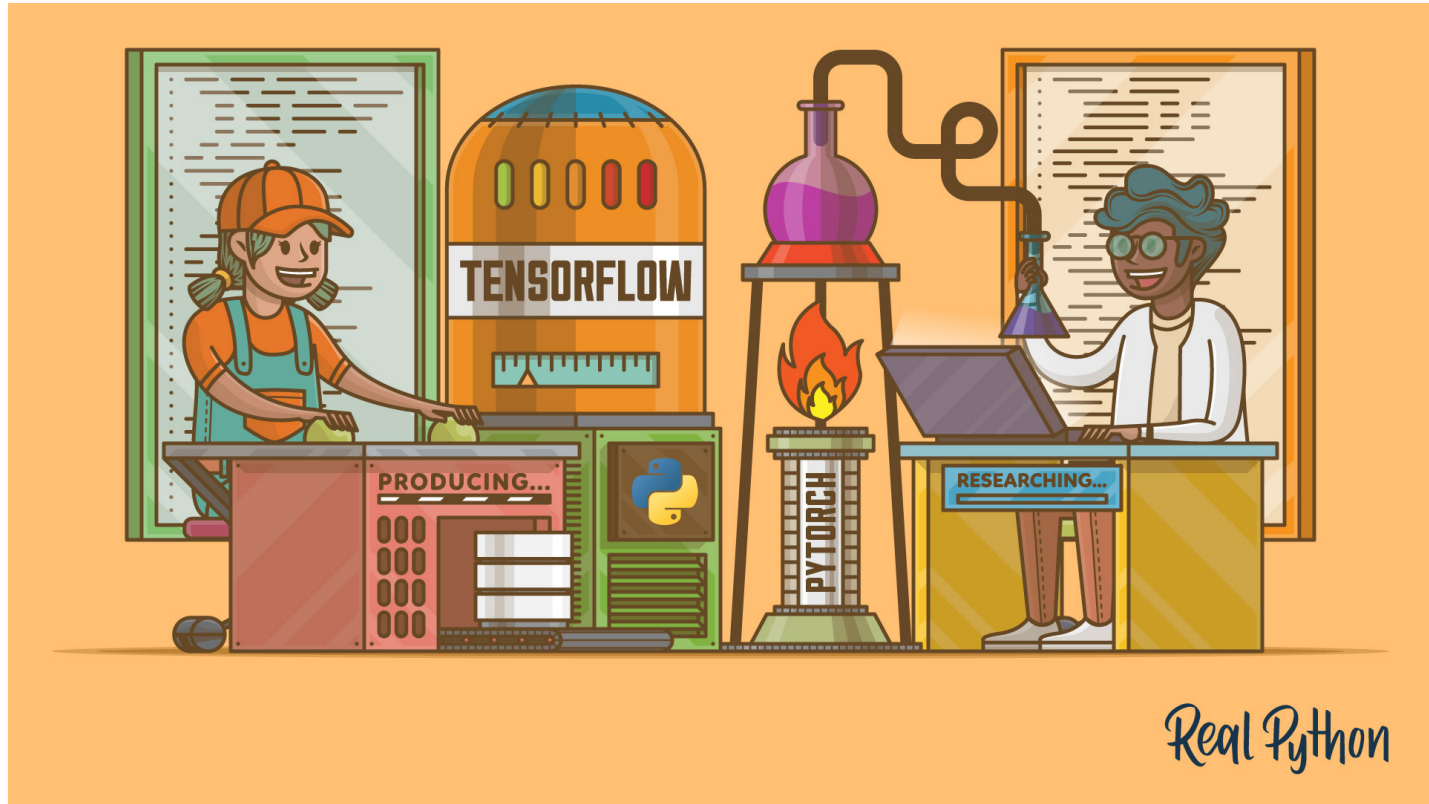

[PyTorch vs TensorFlow for Your Python Deep Learning Project](#)

Deep Learning Frameworks (3)

- [Keras](#): popular API works with TensorFlow 2.0, provides good support at architecture level

Keras



- “Deep learning for humans”
- A popular API works with TensorFlow 2.0, provides good support at architecture level
- Keras now (v2.4) only supports TensorFlow
- Supports CNNs and RNNs and common utility layers like dropout, batch normalization and pooling
- Coding neural networks used to be a LOT harder; Keras makes it easy and accessible!
- Documentation: <https://keras.io/>

Keras: API works with TensorFlow 2.0

```
model = keras.Sequential(  
    [  
        keras.Input(shape=input_shape),  
        layers.Conv2D(32, kernel_size=(3, 3), activation="relu"),  
        layers.MaxPooling2D(pool_size=(2, 2)),  
        layers.Conv2D(64, kernel_size=(3, 3), activation="relu"),  
        layers.MaxPooling2D(pool_size=(2, 2)),  
        layers.Flatten(),  
        layers.Dropout(0.5),  
        layers.Dense(num_classes, activation="softmax"),  
    ]  
)
```

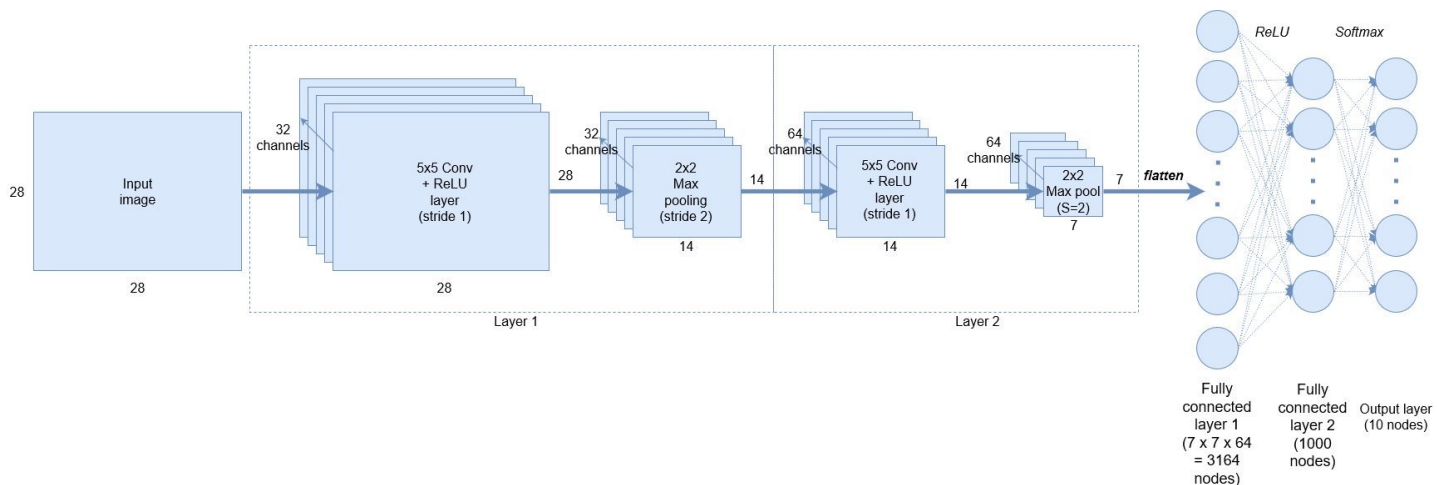

NNs Good at Transfer Learning

- Neural networks effective for [transfer learning](#)
Using parts of a model trained on a task as an initial model to train on a different task
- Particularly effective for image recognition

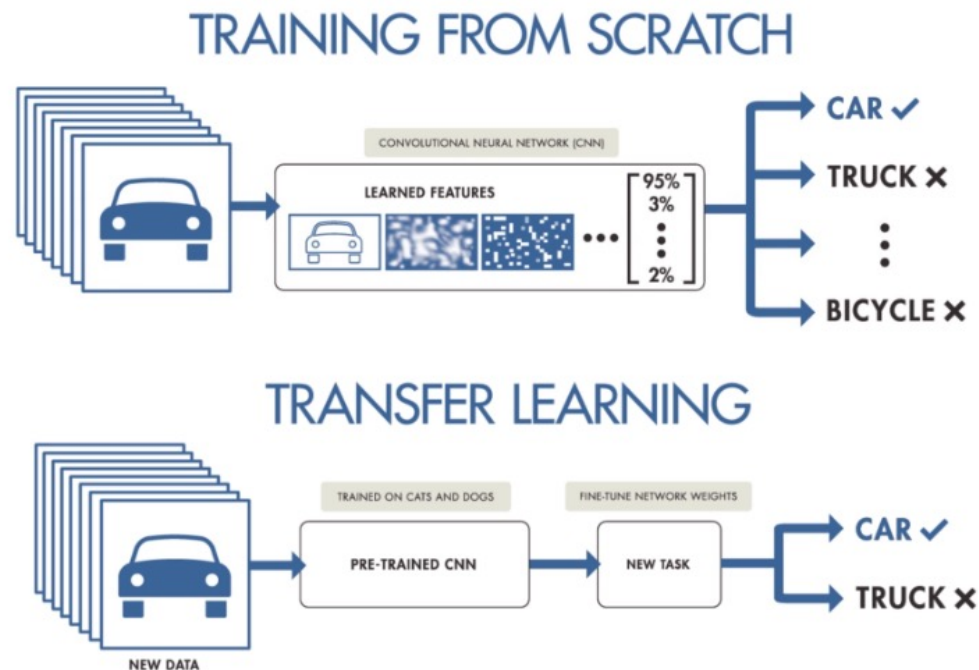

Good at Transfer Learning

- For images, the initial stages of a model learn high-level visual features (lines, edges) from pixels
- Final stages predict task-specific labels

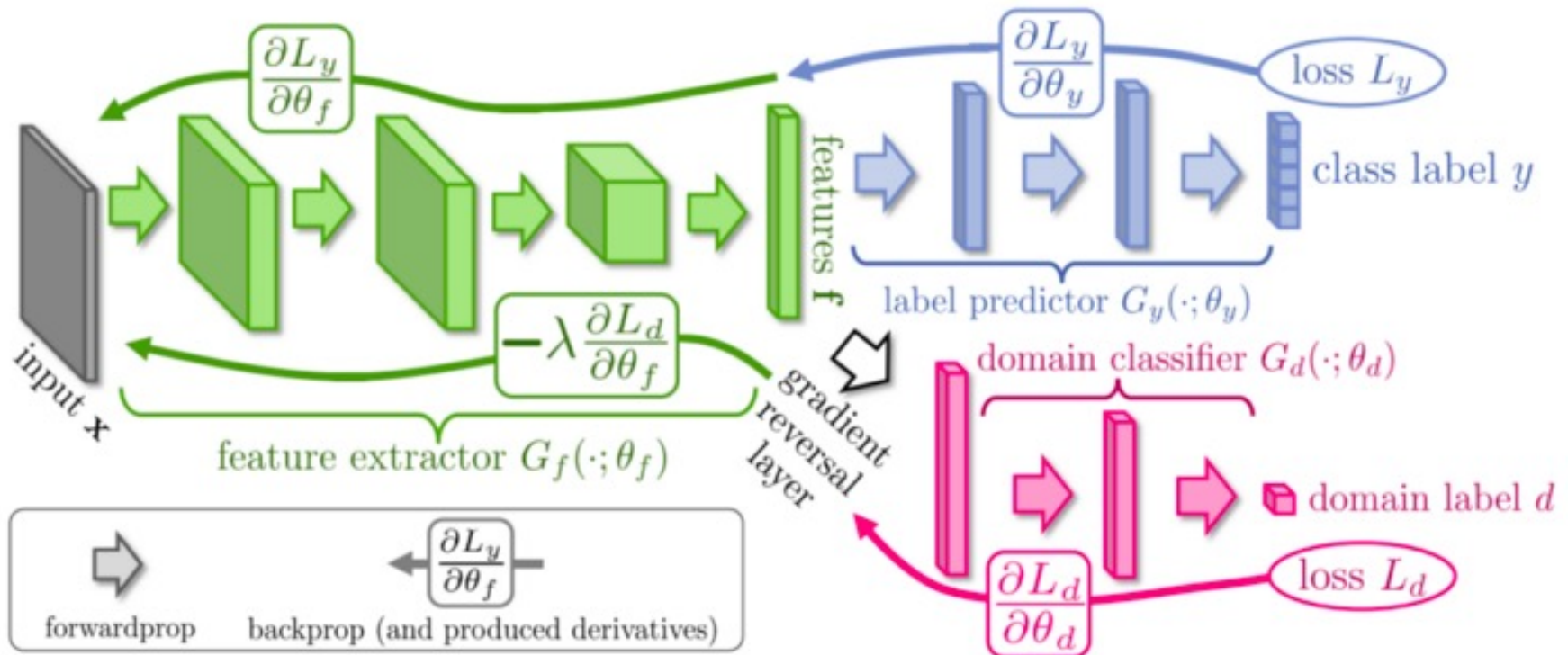

Fine Tuning a NN Model

- Special kind of transfer learning

- Start with a pre-trained model
- Replace last output layer with a new one
- Fix all but last layer by marking as trainable:false

- Retraining on new task and data very fast

- Only the weights for the last layer are adjusted

- Example

- Start: NN to classify animal pix with 100s of categories
- Finetune on new task to classify pix of 10 common pets

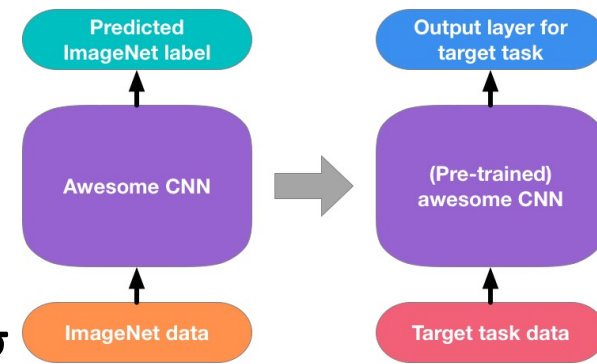

Conclusions

- Quick intro to neural networks & deep learning
- Learn more by
 - Take UMBC's [CMSC 478](#) machine learning class
 - Try scikit-learn's [neural network models](#)
 - Explore Keras as : <https://keras.io/>
 - Explore Google's [Machine Learning Crash Course](#)
 - Work through examples
- and then try your own project idea